

(No Model.)

4 Sheets—Sheet 1.

C. P. TOPPING. MULTIPLE SPINDLE LATHE.

No. 573,726.

Patented Dec. 22. 1896.

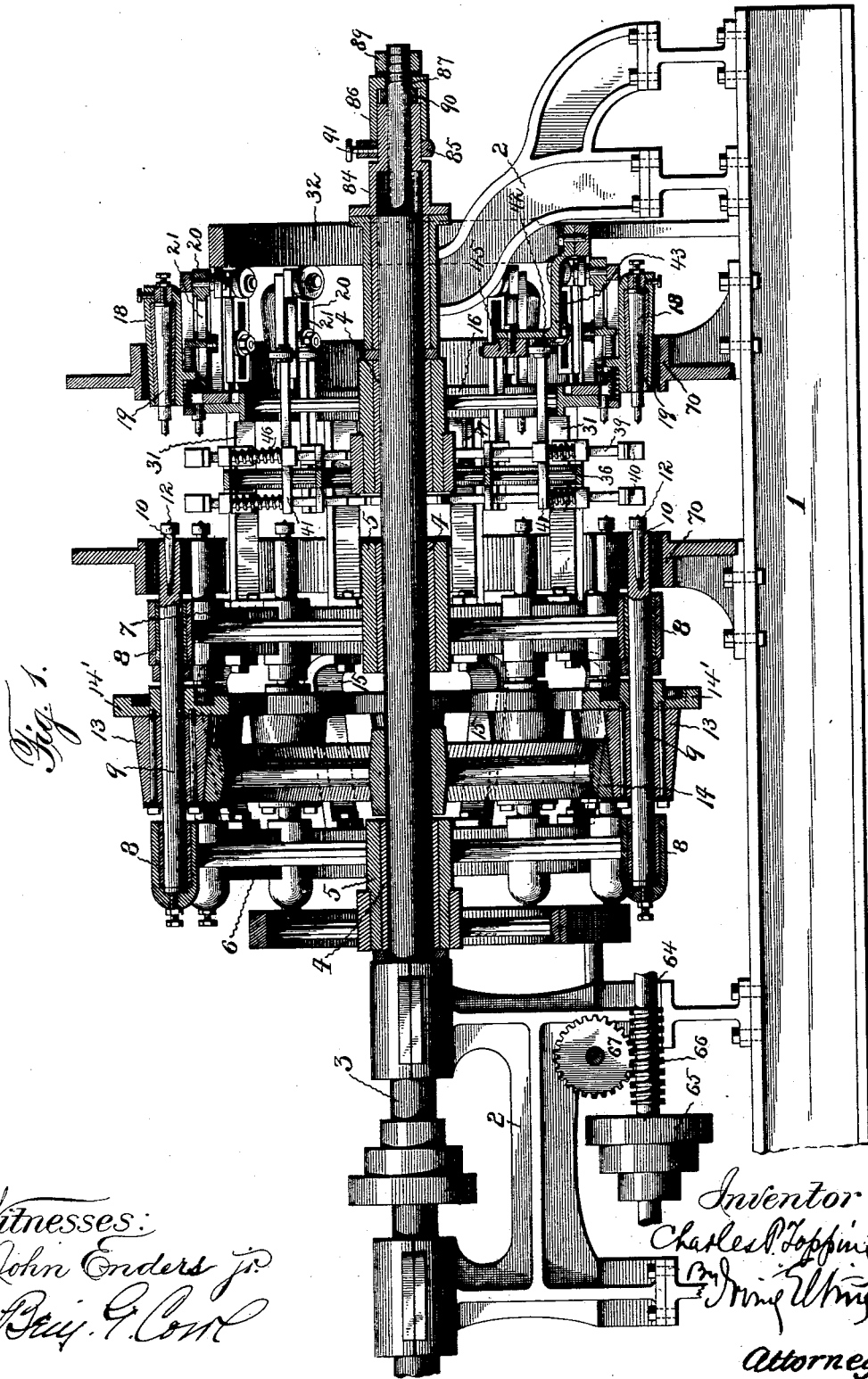

Fig. 1.

Witnesses:
John Enders jr.
Benj. G. Cook

Inventor
Charles P. Topping
By *John W. King*

Attorney.

C. P. TOPPING.
MULTIPLE SPINDLE LATHE.

No. 573,726.

Patented Dec. 22, 1896.

Fig. 2.

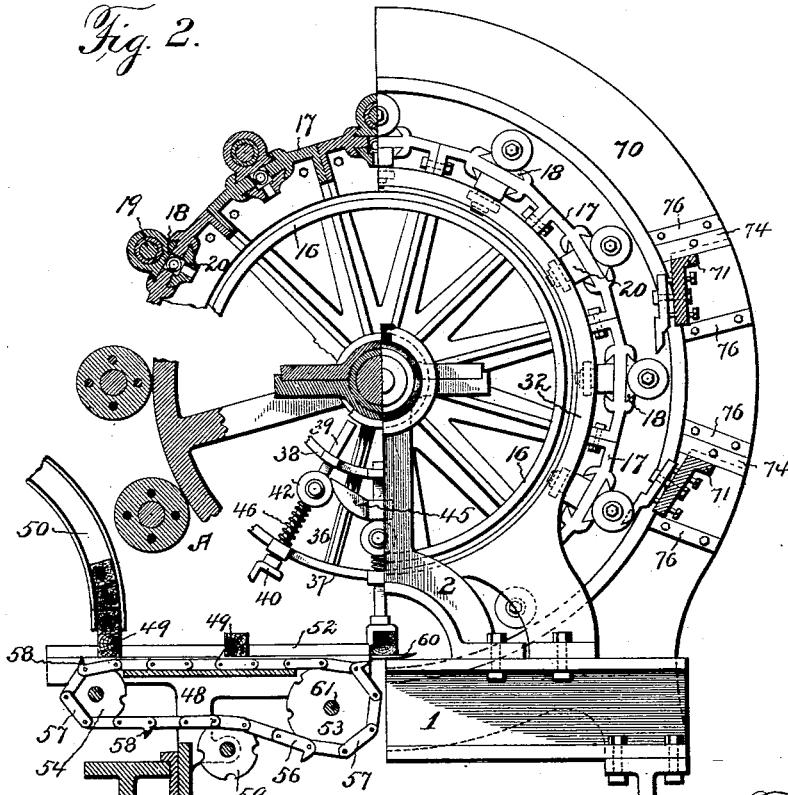

Fig. 3.

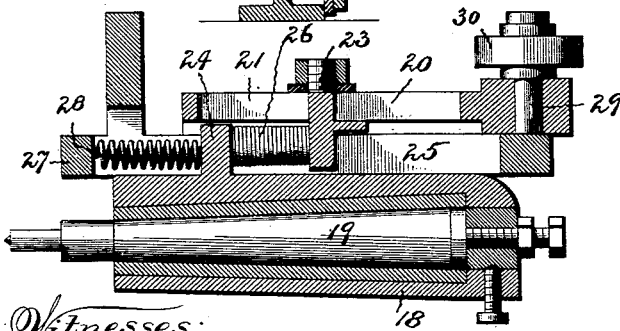
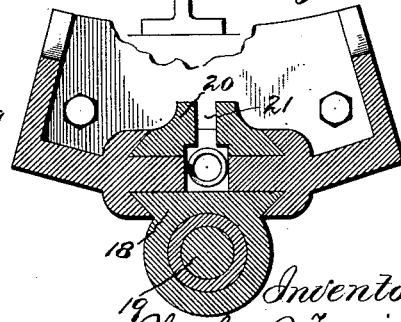

Fig. 4.



Witnesses:

John Anders, jr.
Benj. G. Cook

Inventor:
Charles P. Topping
By Irving Utting
Attorney.

(No Model.)

4 Sheets—Sheet 3.

C. P. TOPPING.
MULTIPLE SPINDLE LATHE.

No. 573,726.

Patented Dec. 22, 1896.

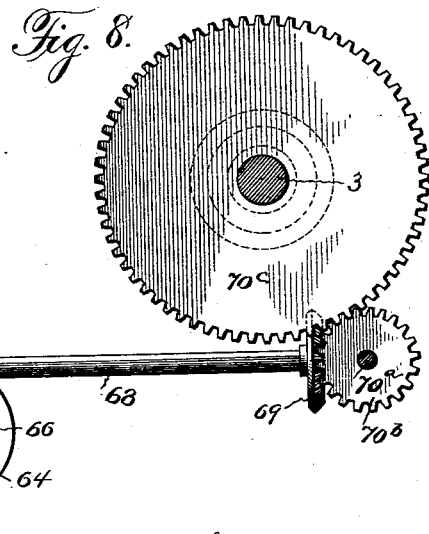
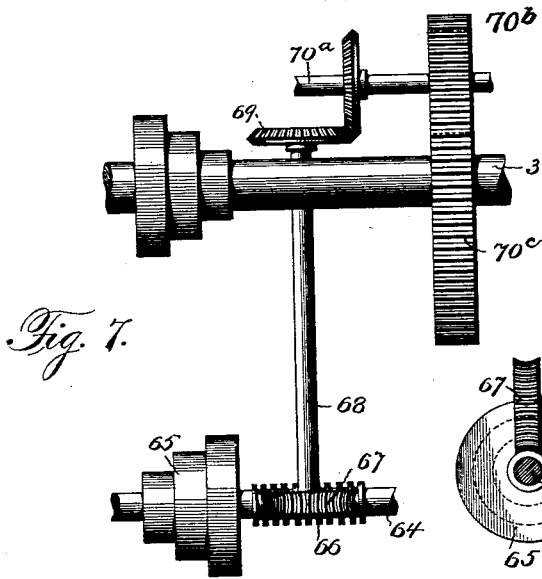
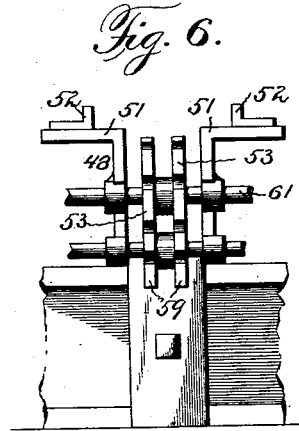
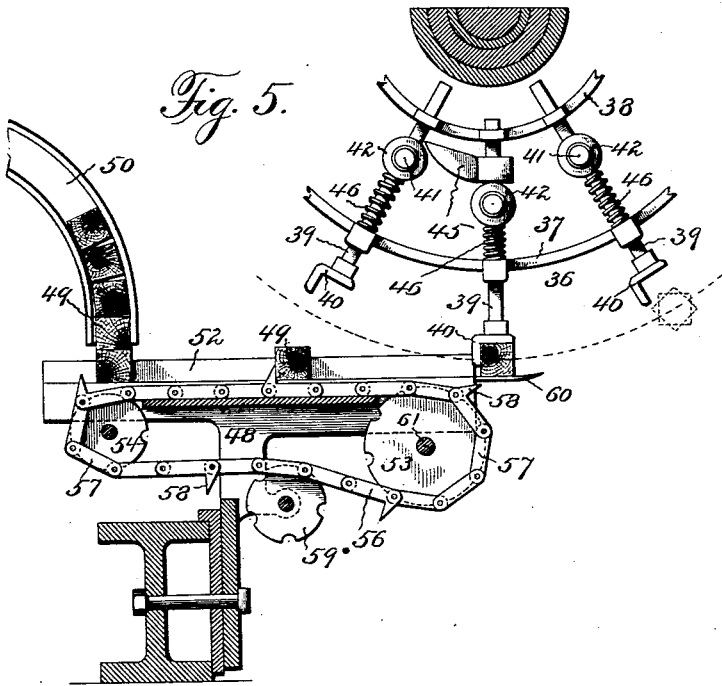

Witnesses:
 John Enders, Jr.
 Benj. C. Coml

Inventor:
 Charles P. Topping
 By Irving Utting
 Attorney.

C. P. TOPPING.
MULTIPLE SPINDLE LATHE.

No. 573,726.

Patented Dec. 22, 1896.

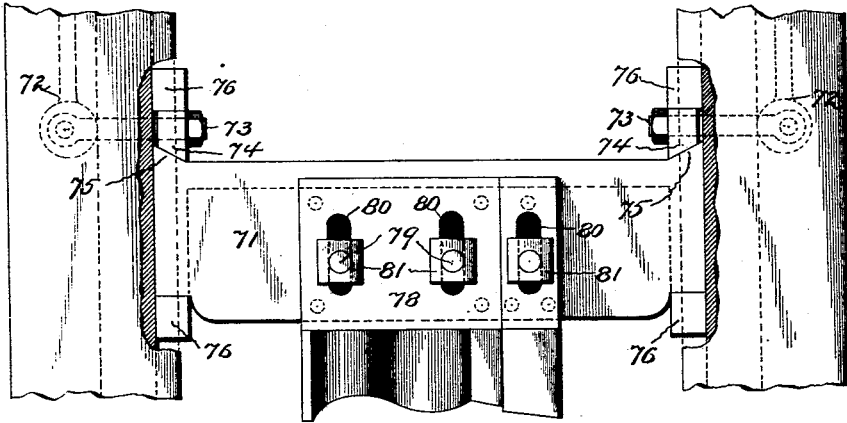

Fig. 9.

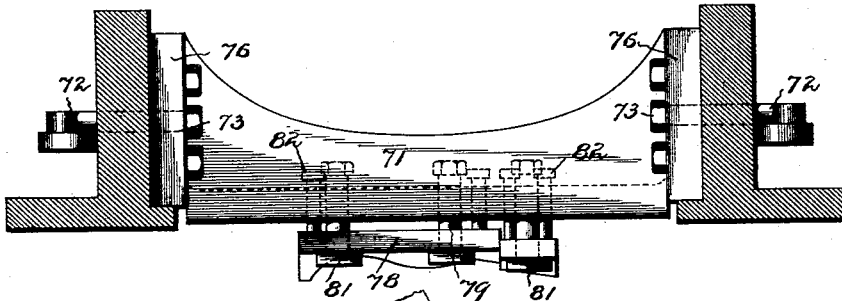

Fig. 10.

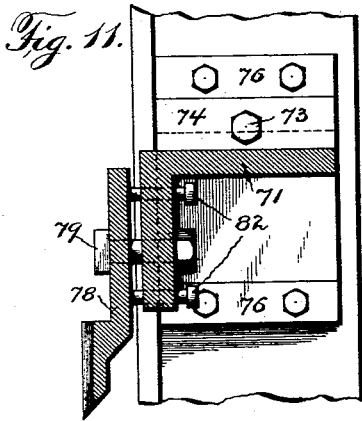

Fig. 11.

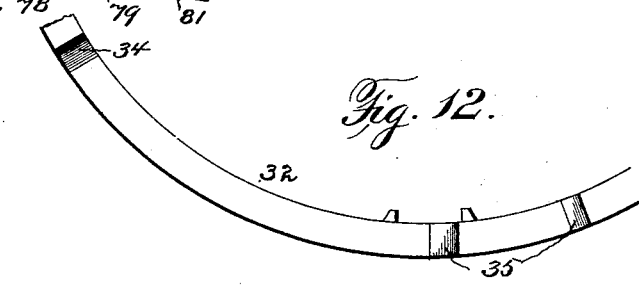

Fig. 12.

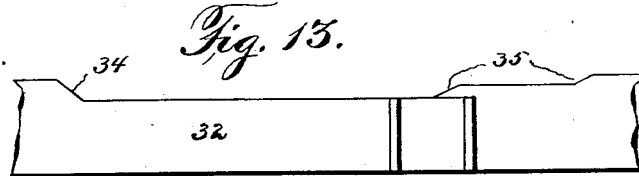

Fig. 13.

Witnesses:
 John Anders jr.
 Ben G. Cook

Inventor:
 Charles P. Topping
 By Irving Utting
 Attorney.

UNITED STATES PATENT OFFICE.

CHARLES P. TOPPING, OF POUGHKEEPSIE, NEW YORK.

MULTIPLE-SPINDLE LATHE.

SPECIFICATION forming part of Letters Patent No. 573,726, dated December 22, 1896.

Application filed June 25, 1895. Serial No. 554,023. (No model.)

To all whom it may concern:

Be it known that I, CHARLES P. TOPPING, a citizen of the United States, residing at Poughkeepsie, in the county of Dutchess and State of New York, have invented certain new and useful Improvements in Multiple-Spindle Lathes; and I do hereby declare the following to be a full, clear, and exact description of the invention, such as will enable others skilled in the art to which it appertains to make and use the same.

My invention relates to improvements in multiple or many spindle lathes for turning articles, such as tool-handles, from wood and other materials, and in which the blanks are automatically fed by means of feeding-jaws to chucking-jaws which grasp and rotate the same and present them to stationary cutters which form them into the desired shape.

The object of the invention is to provide a lathe of the above character which shall possess superior advantages with respect to efficiency in operation; and it consists in the novel construction and combination of parts hereinafter fully described and claimed.

In the accompanying drawings, Figure 1 is a longitudinal sectional view of a lathe constructed in accordance with my invention. Fig. 2 is an end elevation, partly in section. Fig. 3 is a longitudinal sectional view showing one of the movable chuck-spindles and connections. Fig. 4 is a cross-sectional view of the same. Fig. 5 is a detail elevation showing the manner of feeding the blanks or blocks to the feeding-jaws. Fig. 6 is a detail end view of the blank or block delivering mechanism. Fig. 7 is a detail side view showing the mechanism for rotating the cylinder. Fig. 8 is an end elevation of the same. Fig. 9 is a detail elevation of one of the knives or cutters and connections. Fig. 10 is a longitudinal section of the same. Fig. 11 is a cross-section. Figs. 12 and 13 are detail views of the cam-ring by which the movable spindles are moved to and from the work.

In the said drawings the reference-numeral 1 designates the bed-piece or frame of the lathe, to which are secured brackets 2, in which is journaled the main spindle or shaft 3, which is rotated through any suitable motor. Loosely journaled on said shaft are sleeves 4, to which are secured the hubs 5 of

spiders 6 and 7, provided at their peripheries with a series of bearings 8, in which are journaled the high-speed spindles 9. Any number of these bearings and spindles found convenient may be employed, twelve being shown in the present instance. These bearings and spindles are concentric with shaft 3 and are provided with removable centers 10, provided with chucking-jaws 12. Secured to said spindles are a friction-cone 13 and a fly-wheel 14, which cone engages with the beveled periphery of a driving-wheel 14, secured to shaft 3, so that as the latter is rotated the said spindles will be rotated at a much higher speed. The spiders 6 and 7 are connected together by curved plates 15, so that they revolve in unison. Also mounted on a sleeve 4, loosely journaled to shaft 3, is a spider 16, having a number of segments 17, the outside of each of which is formed with a dovetailed groove in which is seated a correspondingly-dovetailed spindle-socket or bearing 18, which are alined with the bearings or sockets 8. In these sockets are journaled the tail-spindles 19, also provided with chucking-jaws. The spindles and spindle-sockets are adjustable to and from the blanks by moving the adjusting-bolt 23 in or out, as the case may be. On the inside these segments are formed with dovetailed grooves in which is seated a dovetailed block 20, formed lengthwise with a slot 21, and in this slot is located an adjusting-bolt 23, and a little to one side of the same is a lug 24, which passes through a slot 25 in the segment. Between the lug just mentioned and the adjusting-bolt is a coiled spring 26, and between lug 24 and a lug 27 is a similar spring 28, the purpose of which springs will be hereinafter apparent. At the rear end of block 20 is a stud-shaft 29, on which is journaled a pressure-roller 30. The dovetailed spindle-sockets and the dovetailed blocks slide freely in their respective grooves.

The spiders 7 and 16 are connected together by means of straight intermediate pieces or plates 31, and these spiders and plates in connection with the spider 6 and its connecting plates or pieces form a cylinder which revolves on the shaft 3. The pressure-rollers 30 bear continually upon a cam-ring 32, secured to the frame of the machine, and is formed with depressions 34 and 35, by means of which the

tail-spindles are forced inward to seize the blanks and clamp them between said spindles and the revolving spindles and present the blanks to the cutters, and then move the tail-spindle outward to disengage the completed or finished article.

Located on the inner end of the hub of spider 16 is a spider 36, which has an outside rim 37 and an inner ring 38 on either side. Through this rim and lug pass rods 39, on the outer ends of which are feeding-jaws 40, which feed the blanks to the spindles. Midway between said rim and ring and secured to the rods 39 are arms 41, to which are secured rollers 42. Secured to the cam-ring 32 is an inwardly-projecting bracket 43, provided with a cam 45, with which the rollers 42 are adapted to engage as the cylinder revolves and the feeding-jaws are moved in and out to be engaged with and disengaged from the blanks.

Embracing the rods 39 and confined between the arms 41 and the rim of spider 36 are coiled springs 46, the object of which is to force the rods inwardly at the proper times and disengage the feeding-jaws from the blanks. The spider 36, rods 39, jaws 40, and arms 41 constitute the feeding mechanism for feeding the blanks from the delivery-chains to the spindles and revolves with the cylinder.

The numeral 47 designates an arm connecting the spiders 16 and 36, and by loosening the bolt connecting said parts the spider 36 may be turned on the hub of spider 16 to adjust the feeding-jaws, that is to say, the jaws can be moved in the line of the orbit of the spindles, so as to bring them nearer to or farther from the center line of the spindles, as the case may be. The feeding-jaws are adjustable radially by moving the cam 45 in or out.

The numeral 48 designates a frame, bolted to the bed or frame of the machine, which carries the mechanism for delivering the blanks 49 from a hopper 50 to the feeding-jaws and comprises in its structure the horizontal ways 51, provided with guide-plates 52. Journaled in this frame are sprockets 53 and 54, the former being the driving-sprocket, around which pass endless chains 56, consisting of pivoted links 57. At suitable intervals apart two alined links of the chains are formed with dogs 58, which engage with the blanks delivered from the hopper and deliver them to the feeding-jaws.

The numeral 59 designates idlers over which the sprocket-chains pass. A spring 60, secured to the frame 48, holds the block of wood or blank up against the feeding-jaws, while the center of the tail-spindle is brought up against it by means of the pressure-roller and cam-ring.

The numeral 61 designates the shaft of the driving-sprockets, which is connected by a sprocket-wheel and chain (not shown) with a shaft 64. This shaft 64 is provided with pul-

leys 65, connected by belts (not shown) with the shaft 3, and is provided with a worm 66, which meshes with a worm-wheel 67 on a shaft 68, provided with a bevel-gear 69, which meshes with a corresponding bevel-gear on a shaft 70^a. This shaft is provided with a pinion 70^b, which meshes with a cog-wheel 70^c, secured to the cylinder. By this construction the cylinder will rotate very slowly, while the shaft 3 will rotate very rapidly.

The numeral 70 designates two large rings, which encircle the complete cylinder and are bolted to the bed-piece 1. Between these rings are located the tool-bridges 71, being secured to the rings by means of cam-levers 72 and bolts 73, which are connected with beveled pieces 74, which engage with the beveled portions 75 of the tool-bridges.

The numeral 76 designates blocks secured to the rings, between which the ends of the tool-bridges and beveled pieces are clamped by means of the cam-lever.

The numeral 78 designates the tool or cutter which is secured by bolts 79 to the bridges. These bolts pass through slots 80 in the bridges, so as to be adjustable, and are held in place by nuts 81.

The numeral 82 designates set-screws for adjusting the tool or cutters. The cutters may be of any form and any number found convenient or desirable.

For the purpose of increasing the frictional contact between the cones on the high-speed spindles and the driving-wheel 14, I provide the following means: On the rear end of the shaft 3 and bolted to a bracket 2 is a sleeve 84, which is threaded to fit a nut 85. On the threaded part of sleeve 84 and secured to or forming part of nut 85 is a sleeve 86, provided with a collar 87, against which bears a collar 89, secured to the outer end of shaft 3. Located inside of sleeves 86 is a collar 90, secured to shaft 3. The nut 85 is provided with a set-screw 91, by loosening which and turning the nut the shaft 3 may be moved in and out so as to vary the pressure between the said cone and driving-wheel.

The operation is as follows: The machine is so geared and timed that the cylinder should make about two revolutions a minute, while the shaft 3 should make about seven hundred and the spindles about four thousand. The shaft is rotated by any suitable means, and by the gearing the cylinder is revolved in an opposite direction, causing the friction driving-wheel 14 to rapidly rotate the spindles. As the cylinder revolves, the blanks are delivered to the feeding-jaw and fed to the spindles as they successively come into position, and the pressure-rollers of the tail-spindles working in the cam-ring will cause the tail-spindle to be forced inward so as to grasp the blank between it and the revolving spindle alined therewith. At the same time the said spindles clamp the blank the rollers of the feeding-arms will have passed off their cams and the coiled springs

will force the jaws inward so as to disengage them from the blocks or blanks. The blocks or blanks are now carried around by the cylinder so as to be operated upon by the cutters, which will fashion them into the desired shape. When the finished article reaches a point about where marked A, Fig. 2, the pressure-roller will engage with the depression 34 in the cam-ring, when the spring 28 will force the tail-spindle outward and release the article. The roller will then engage with the next but shallower depression 35, which will force the tail-spindle inward, but so that when the next blank is to be gripped the said spindle will come into contact with the end thereof, so that on the roller striking the cam-face of the ring it will be quickly forced into engagement with the blank and clamp the same between it and the rotatable spindle. The spring 23 is for the purpose of affording a yielding bearing between the movable spindles and the pressure-roller, which will allow of a slight variation in the lengths of the blanks.

Many modifications or changes may be made in the machine without departing from the principle of my invention, and I therefore do not limit myself to the specific details of construction herein shown and described.

Having thus fully described my invention, what I claim is—

1. In a multiple-spindle lathe, the combination with the horizontally-adjustable rotating shaft and means for adjusting the same, of the oppositely-rotating cylinder, the rotatable spindles and cooperating means whereby the speed of said spindles is increased and decreased by the horizontal movement of said shaft, the tail-spindles, and means for moving said tail-spindles to and from the rotatable spindles, substantially as described.

2. In a multiple-spindle lathe, the combination with the horizontally-adjustable rotating shaft, the spiders loosely mounted thereon and rotating in the opposite direction, the rotatable spindles, the tail-spindles, and the friction-cones on said rotatable spindles, of the driving-wheel secured to said shaft having a beveled periphery engaging with said cones and fixed to and rotating with said shaft, substantially as described.

3. In a multiple-spindle lathe, the combination with the horizontally-adjustable rotating shaft and means for adjusting the same, the spiders loosely mounted thereon and rotatable in the opposite direction, the rotatable spindles, the tail-spindles, and the friction-cones on said rotatable spindles, of the driving-wheel secured to said shaft having a beveled periphery engaging with said cones, substantially as described.

4. In a multiple-spindle lathe, the combination with the bed or base, the brackets, the shaft, driving-wheel the spiders, the rotating and tail spindles, and the friction-cones engaging with said wheel, of the screw-threaded sleeve secured to one of said brackets, the

nut engaging therewith, the sleeve, the collar and nut and the collar located in said sleeve, substantially as described.

5. In a multiple-spindle lathe, the combination with the rotating shaft, the oppositely-rotating spiders mounted loosely thereon, the rotatable spindles provided with friction-cones, and the driving-wheel secured to said shaft, of the rotatable spider, the sockets or bearings provided with a lug, the tail-spindles, the slotted segments and adjusting-bolts, the laterally-movable blocks, the pressure-roller, and the cam-ring, substantially as described.

6. In a multiple-spindle lathe, the combination with the bed or base, the brackets, the rotating shaft, the oppositely-rotating spiders loosely mounted thereon, the rotatable spindles, the friction-cones, and the beveled driving-wheel fixed to said shaft, of the rotatable spider, provided with sockets or bearings provided with a lug, the tail-spindles, the slotted segments and adjusting-bolts, the laterally-movable spring-actuated blocks, the pressure-rollers and the cam-ring, substantially as described.

7. In a multiple-spindle lathe, the combination with the bed or base, the brackets, the rotating horizontally-adjustable shaft, the oppositely-rotating spiders, the friction-cones, the beveled driving-wheel engaging therewith, the sockets or bearings provided with a lug, the tail-spindles, the slotted segments, the adjusting-bolts, the adjustable blocks, the pressure-rollers, and the cam-ring provided with a series of depressions, substantially as described.

8. In a multiple-spindle lathe, the combination with the shaft, the cylinder, the speed-spindles, the friction-cones, the beveled driving-wheel, the tail-spindles and connections, and means for laterally moving the same, of the spider provided with a rim and ring, the radially-movable feeding arms and jaws, the coiled springs encircling said arms the cam, the bracket to which said cam is secured the arms secured to said feeding-arms, the rollers journaled thereto and adapted to engage with said cam, substantially as described.

9. In a multiple-spindle lathe, the combination with the bed or base, the brackets, the rotatable shaft, the oppositely-rotatable cylinder, the rotatable spindles, the friction-pulleys, the beveled driving-wheel fixed to said shaft, the tail-spindles, and means for laterally moving the same, of the spider provided with a rim and ring, the spring-actuated feeding arms and jaws, the arms secured thereto, the rollers journaled to said arms, the bracket, the cam adjustably secured thereto with which said rollers engage, and the arm connecting the spider last mentioned with the spider carrying the tail-spindles, substantially as described.

10. In a multiple-spindle lathe of the character described, the combination with the rotatable spider, the spring-actuated feeding-

arms provided with jaws, the arms connected therewith, the rollers and cam, of the endless link chain provided with dogs, the hopper, and means for operating said chain, substantially as described.

11. In a multiple-spindle lathe of the character described, the combination with the rotatable spider having a rim and ring, the radial spring-actuated feeding arms and jaws, the arms connected therewith, the rollers journaled thereto, and the cam, of the endless feed-chain, the sprocket-wheels, and means for operating the same, the dogs on said chain, and the spring for holding the blanks or blocks fed by said chain up against the feeding-jaws, substantially as described.

12. In a multiple-spindle lathe of the character described, the combination with the revolving cylinder and rotating and tail spindles, of the rings, the blocks secured thereto, the beveled tool-bridges, the beveled blocks, the bolts passing therethrough, the cam-lever connected therewith, and the removable and adjustable cutters, substantially as described.

13. In a multiple-spindle lathe of the character described, the combination with the bed, the brackets, the rotating shaft, the oppositely-rotating spiders, the plates connecting the same, the rotatable spindles, the friction-cones, the beveled driving-wheel, the tail-spindles, the sockets, the horizontally-movable spring-actuated blocks, the pressure-rollers, the cam-ring formed with depressions, the rings and the adjustable cutters secured thereto, substantially as described.

14. In a multiple-spindle lathe of the char-

acter described, the combination with the bed or base, the rotating shaft, the oppositely-rotating cylinder, the friction-cones, the beveled driving-wheel, the rotating spindles, the spider journaled to said shaft and carrying the tail-spindles, the sockets, the spring-actuated blocks, the pressure-rollers, and the cam-ring, of the rim and ring at the inner end of the said cylinder, the feeding arms and jaws, the arms and rollers, the cam, the delivery-chain, and means for operating the same, and the rings and adjustable cutters, substantially as described.

15. In a multiple-spindle lathe of the character described, the combination with the horizontally-adjustable main shaft, the cylinder rotating in the opposite direction, the rotating spindles, the driving-wheel secured to said shaft and cooperating mechanism for driving said spindles the engagement of which is governed by the horizontal movement of said shaft, of the cog-wheel secured to said cylinder, the pinion engaging therewith, the counter-shaft to which said pinion is secured, the beveled pinion on said shaft, the corresponding pinion meshing therewith, the horizontal shaft, the worm-wheel, the worm-shaft, the pulleys fixed thereon, and the pulleys on the main shaft, substantially as set forth.

In testimony whereof I affix my signature in presence of two witnesses.

CHARLES P. TOPPING.

Witnesses:

IRVING ELTING,
MARTIN HEERMANCE.